



**KLT-IRSW-OV4682 V2.0**  
**OmniVision OV4682 with IR Switch MIPI Interfaz Foco fijo 4MP M12**  
**Módulo de cámara**



<b>Módulo de cámara No.</b>	<b>KLT-IRSW-OV4682 V2.0</b>	
<b>Sensor de imagen</b>	OV4682	<b>IR SWITCH</b>
<b>EFL</b>	3.1 mm	Input Voltage: 4V ~ 12V
<b>F.NO</b>	1.8	Operating Current: 88 ~ 300 mA
<b>Pixel</b>	2688 x 1520	Red Line: Positive
<b>Ángulo de visión</b>	140°	Black Line: Negative
<b>Tipo de lente</b>	1/3 pulgada	
<b>Dimensiones de la lente</b>	14.00 x 14.00 x 23.10 mm	Operation:
<b>Tamaño del módulo</b>	57.07 x 30.00 mm	ON: IR Active (Day Time)
<b>Tipo de módulo</b>	Foco fijo	OFF: IR Disable (Night Time)
<b>Interfaz</b>	MIPI	

**N. ° de pieza del conector de acoplamiento. FH12-24S-0.5SH**



Conector de acoplamiento en la placa principal. Se vende por separado.

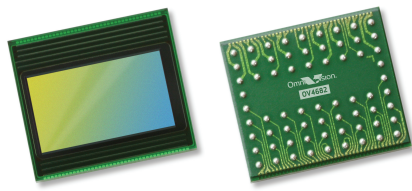

# OV4682 4MP product brief



Day Light

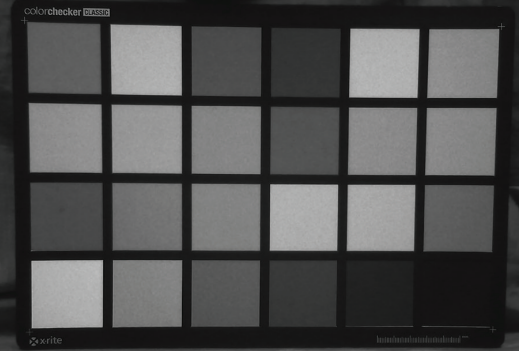

0 Lux - IR Strobe

## Dual-Purpose RGB IR CameraChip™ Sensor Brings High Sensitivity and High Frame Rates to Mobile and Machine Vision Applications



available in a lead-free package

OmniVision's OV4682 is a 4-megapixel RGB infrared (IR) single sensor that captures high-resolution images and video as well as IR information. Its dual RGB and IR capabilities allow it to bring a host of additional features to mobile and machine vision applications, including gesture sensing, depth analysis, iris detection and eye tracking. By combining two capabilities into a single sensor, the OV4682 reduces the total cost for the system while also reducing the space required for multiple sensors.

The sensor's 2-micron OmniBSI-2™ pixel delivers excellent signal-to-noise ratio and IR sensitivity, and offers best-in-class low-light sensitivity with a 40 percent increase in sensitivity compared to the 1.75-micron OmniBSI-2 pixel. The OV4682's unique architecture and pixel optimization bring not only the best IR performance

but also best-in-class image quality. Additionally, the sensor reduces system-level power consumption by optimizing RGB and IR timing.

The OV4682 records full-resolution 4-megapixel video in a native 16:9 format at 90 frames per second (fps), with a quarter of the pixels dedicated to capturing IR. The 1/3-inch sensor can also record 1080p high definition (HD) video at 120 fps with electronic image stabilization (EIS), or 720p HD at 180 fps.

The OV4682 features a high-speed 4-lane MIPI serial output interface to facilitate the required high data transfer rate. It fits into an 8.5 x 8.5 mm module with a z-height of less than 6 mm.

Find out more at [www.ovt.com](http://www.ovt.com).



## Applications

- Cellular Phones
- Tablets
- Digital Still Cameras (DSC)
- Digital Video Camcorders (DVC)
- PC Multimedia
- Security
- Gaming
- Gesture Detection

## Product Features

- automatic black level calibration (ABLC)
- programmable controls for frame rate, mirror and flip, cropping, and windowing
- static defective pixel canceling
- supports output formats: 10-bit RAW RGB-IR (MIPI)
- supports horizontal and vertical subsampling
- supports images sizes: 4MP, 3MP, EIS1080p, 1080p, EIS720p
- fast mode switching
- support 2x2 binning, 4x4 binning, re-sampling filter
- standard serial SCCB interface
- up to 4-lane MIPI serial output interface
- embedded 4K bits one-time programmable (OTP) memory for part identification, etc.
- two on-chip phase lock loops (PLLs)
- programmable I/O drive capability
- built-in temperature sensor

# OV4682

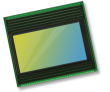

## Ordering Information

- OV04682-G04A-1D**  
(RGB-IR, chip probing, 200  $\mu\text{m}$  backgrinding, reconstructed wafer with good die)

## Product Specifications

- active array size:** 2688 x 1520
- lens chief ray angle:** 21° non-linear
- power supply:**
  - core: 1.1 - 1.3V
  - analog: 2.6 - 3.0V
  - I/O: 1.7 - 3.0V
- power requirements:**
  - active: 163 mA (261 mW)
  - standby: 1 mA
  - XSHUTDOWN: <10  $\mu\text{A}$
- temperature range:**
  - operating: -30°C to +85°C junction temperature
  - stable image: 0°C to +60°C junction temperature
- output formats:** 10-bit RAW RGB data
- lens size:** 1/3"
- input clock frequency:** 6 - 64 MHz
- maximum image transfer rate:**
  - 2688x1520: 90 fps
  - 1920x1080: 120 fps
  - 1280x720: 180 fps
  - 672x380: 330 fps
- scan mode:** progressive
- maximum exposure interval:** 1548 x T<sub>ROW</sub>
- pixel size:** 2  $\mu\text{m}$  x 2  $\mu\text{m}$
- dark current:** 4 mV/sec @ 60°C junction temperature
- image area:** 5440  $\mu\text{m}$  x 3072  $\mu\text{m}$
- die dimensions:**
  - COB: 6600  $\mu\text{m}$  x 5800  $\mu\text{m}$
  - RW: 6650  $\mu\text{m}$  x 5850  $\mu\text{m}$

## Functional Block Diagram

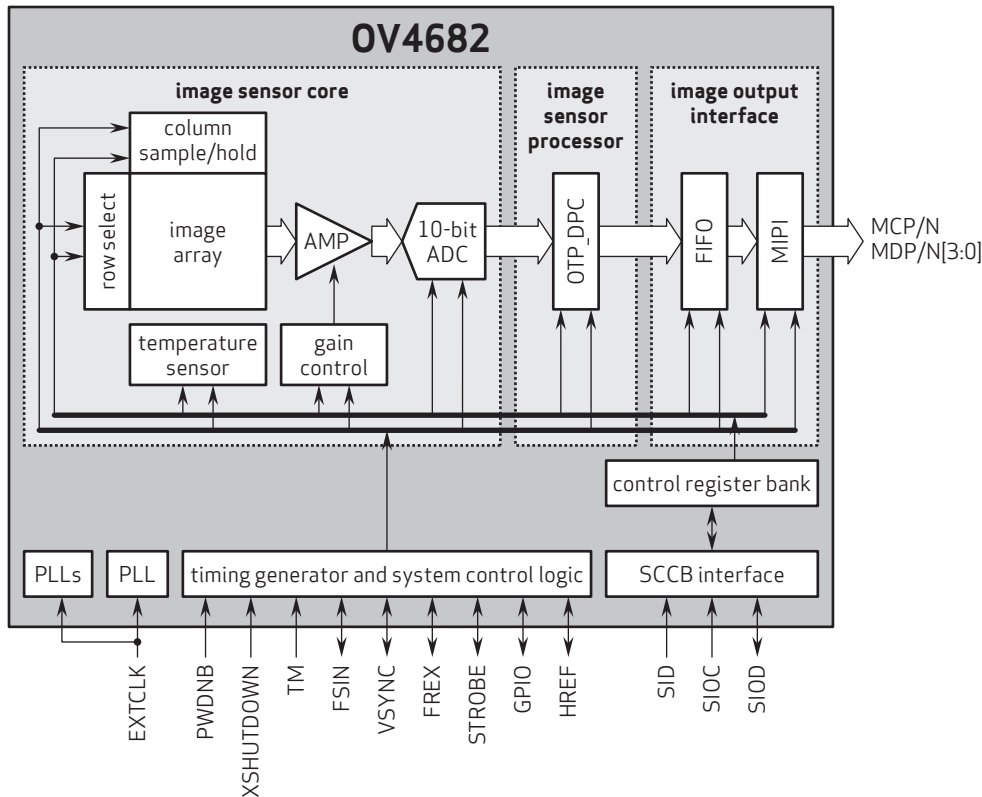

4275 Burton Drive  
Santa Clara, CA 95054  
USA

Tel: + 1 408 567 3000  
Fax: + 1 408 567 3001  
www.ovt.com

OmniVision reserves the right to make changes to their products or to discontinue any product or service without further notice. OmniVision and the OmniVision logo are registered trademarks of OmniVision Technologies, Inc. CameraChip and OmniBSI-2 are trademarks of OmniVision Technologies, Inc. All other trademarks are the property of their respective owners.



**OmniVision**